



Social learning in common ravens, *Corvus corax*

JOHANNES FRITZ & KURT KOTRSCHAL

Konrad Lorenz Forschungsstelle and Institute of Zoology, University of Vienna

(Received 21 February 1998; initial acceptance 15 April 1998;
final acceptance 23 November 1998; MS. number: 5792R)

We conducted an experiment to investigate whether the presence of a conspecific model can promote the acquisition of a motor task in common ravens. For this purpose, dyads, either of control birds or of model–observer pairings, were allowed to operate together in an arena with a set of identical boxes. Each box consisted of two compartments each containing a reward of three pieces of meat. The compartments were closed by gliding lids with red flaps on their front, opening horizontally in opposite directions. Naive control individuals opened the lids exclusively by levering, that is, jumping on top of the box, inserting the beak at the posterior rim of the lid and pushing it open. Models were trained to demonstrate an alternative opening technique, pulling at the front flap, then jumping on top of the box to get at the reward. In contrast to the control birds, observers initially opened boxes both ways, by pulling and levering. Furthermore, observers approached the boxes more quickly and showed less fearful behaviour than the control birds, which we attribute to the enhancing effect of the model. We discuss both stimulus enhancement and motor imitation as possible learning mechanisms. Even though observers initially obtained a considerable amount of reward produced by the models, scrounging evidently did not inhibit learning.

© 1999 The Association for the Study of Animal Behaviour

We present experimental evidence that birds with a reputation of being particularly ‘intelligent’, common ravens, are able to gather information about a specific motor task by observing and interacting with a conspecific model. Ravens are ecologically highly adaptable and are both neophobic and neophilic (Heinrich 1988, 1995). They are long-term monogamous and territorial for most of their life. However, subadults and adult nonbreeders join fission–fusion groups (Heinrich 1989; Huber 1991). Flocking may serve to overcome the territorial defence of conspecifics in competition for food, or may even allow ravens to divert food from predators, such as wolves (Heinrich 1989; Promberger 1992). In addition, flocking may facilitate the formation of local traditions by different mechanisms of social learning.

In line with our interest in the mechanisms of information transfer within groups of nonbreeding ravens, we designed an experiment on social learning that did not affect experimental vigour while being as valid as possible in relation to the natural behaviour of ravens. We used nine hand-reared birds to test the influence of a trained conspecific model on learning a specific motor task in naive observers. The ability to gather information from others has important implications for the transmission of new behaviour patterns within a population, regardless

of the specific learning mechanism involved (Sherry & Galef 1990; Nicol & Pope 1994; Zohar & Terkel 1996).

Several different mechanisms may be responsible for learning by observation. Stimulus enhancement refers to instances in which the observation of a model’s activity makes the location or object of the model’s behaviour attractive for an observer (Thorpe 1963; Galef 1988; Campell & Heyes, in press). Heyes (1994) defined stimulus enhancement as one-stimulus learning, involving no association between the location or object and the reward. Observational conditioning, in contrast, is defined as a kind of classical conditioning, where the observer associates the location or object with the reward obtained by the model (Cook et al. 1985; Heyes 1994). Both mechanisms can increase the probability of the observer learning an operant task, whereas motor imitation is defined as learning the operant task directly through the observation of the model’s behaviour (Heyes 1994; Zentall 1996). Imitation is commonly considered as the cognitively most demanding category of social learning, since the translation of a visual input into a matching motor output may involve more complex central processing than other mechanisms of social learning (Whiten & Byrne 1988; Heyes 1998). Although a number of studies have focused on the imitative ability of different primate species (e.g. Byrne 1995; Whiten et al. 1996; Bugnyar & Huber 1997), a few nonprimate mammals, such as rats, *Rattus norvegicus* (Heyes et al. 1992; Heyes

1996), and several bird species, such as budgerigars, *Melopsittacus undulatus* (Galef et al. 1986), grey parrots, *Psittacus erithacus* (Moore 1992), pigeons, *Columba livia* (Zentall et al. 1996) and Japanese quails, *Coturnix japonica* (Akins & Zentall 1996), the conclusiveness of the evidence for imitation learning is still debated (Visalberghi & Frigaszy 1990; Byrne & Tomasello 1995; Heyes 1998; Gardner & Heyes, *in press*). Moreover, studies on 'lower' mechanisms of social learning, such as enhancement or observational conditioning, are rare.

The contemporary method of choice to demonstrate imitation learning by excluding other mechanisms is the two-action procedure (Dawson & Foss 1965), where the experimental set-up allows two alternative possibilities for solving a mechanical task. A trained model demonstrates one of the two options to naive observers. The criterion for imitation learning at work would be a resulting bias of the observers towards the performance shown by the model, whereas control animals, which were not exposed to the model, should not show such a bias ('non-exposed control', Heyes et al. 1992). Additionally, different models may show one of the two alternative actions, for example pushing a lever either towards the left or towards the right. To qualify as imitation learning observers should show a behavioural bias towards the method demonstrated by their model ('pattern control'; Heyes et al. 1992). Nonexposed control and pattern control require two groups of models and observers, tested for the alternative task, and a control group without presentation by a model. Therefore, quite a large number of experimental animals are necessary, which often makes the two-action procedure hard to employ.

As we had few experimental animals, we modified the two-action procedure accordingly by focusing on the behaviour of individuals rather than on population means of observer groups. The two ways to open our testing device, a box with two lids, were designed for 'qualitative asymmetry'. This means that one of the two opening techniques (pulling the lid, see below) was more complex and, therefore, more difficult for ravens than the alternative technique (levering, see below). This was confirmed by the control individuals, which exclusively levered to gain access to the reward. This method allowed us to use only one group of observers, to which the model demonstrated the more difficult technique to solve the task. A similar method was used by Bugnyar & Huber (1997) to demonstrate imitation learning in marmosets, *Callithrix jacchus*. In addition, we avoided a standard feature of recent laboratory testing, the separation of the observer from the model in two different compartments of the testing device. Separation prevents physical contact and inhibits social interactions which, however, may be important in social learning (Coussi-Korbel & Frigaszy 1995; Frigaszy & Visalberghi 1996). We allowed the trained and the naive individual to interact on an experimental arena, which contained a superfluous number of testing devices. As a result we had no separation between the observational phase and the test phase. Therefore, the observers had the option not only to learn socially or to open the lids individually, but also to exploit food the

model had produced ('food-scrounging': Barnard 1984; Giraldeau et al. 1994).

METHODS

Subjects

Nine ravens, all offspring from the same pair, kept at the Vienna Zoological Garden Schönbrunn, participated in this research (Table 1). All individuals were hand reared on an optimal diet which included insects, dead juvenile mice and rats, fruit and ground snail shells. Hand rearing was necessary to obtain tame and cooperative animals for the experiments.

Five of the nine siblings from 1994 were reared from their second week after hatching by one of us (J.F.) in an aviary (8 × 10 × 5 m), which contained a small tree, shrubs, grass and a small stream. Contact with other people was limited. Upon fledging, the birds were encouraged by the foster parent to fly freely outside the aviary. During the course of the experiments, in summer and autumn 1994, the birds integrated themselves into a nearby flock of wild nonbreeders (Kabicher & Fritz 1996). Nevertheless, they voluntarily and regularly returned to participate in the experiments, which started 5 weeks after fledging and lasted for approximately 4 weeks (Table 1). Two of the 1994 individuals were first used as control group 1 and trained as models thereafter. The three remaining individuals were designated as observers.

Another group of four control birds was hand reared in 1995 by G. Kabicher (Kabicher & Fritz 1996). In contrast to the preceding year, the intention was not to release them, but to rear them for captivity. Therefore, before and after fledging these birds were confronted with many novel objects and were allowed friendly social contacts with a number of people. This resulted in individuals that showed little neophobia and were consistently cooperative in a series of experimental projects. These siblings were moved into a newly built circular aviary, 10 m in diameter and 7 m high, and served as control groups 2 and 3 when they were 26 months old.

Apparatus and Opening Techniques

The test box (Fig. 1) was designed in a way that opening involved behaviours used by ravens during natural food acquisition. The boxes consisted of wooden frames (30 × 30 × 10 cm) with a bottom of white polystyrene. Each box was separated into two symmetrical compartments by a central polystyrene divider. These two compartments could be closed by gliding lids which opened in opposite directions. The lids had red plastic flaps (4 × 8 cm) mounted at their fronts. Thus, the closed lids could be opened by the ravens in two different ways, either by pecking between the lid and the central divider and then levering the lid open with their beak or by pulling the flap. Since the first two control birds exclusively levered the lid open to get at the reward, we trained the models to open exclusively by pulling. For this purpose, a strip of polystyrene was screwed on top of the

Table 1. Details of the ravens used in the experiments and the number of testing boxes presented to them

Group	Subject	Gender	Year of hatching and upbringing	Age at beginning of experiment	Box presentation
Observer	Ara	Male	1994 Free flying	14 weeks	6 boxes in the aviary
	Otto	Female	1994 Free flying	13 weeks	6 boxes in the aviary
	Luu	Male	1994 Free flying	13 weeks	6 boxes in the aviary
Control 1/model	Pele	Female	1994 Free flying	11 weeks*	6 boxes outside the aviary
	Ili	Female	1995 Free flying	11 weeks*	6 boxes outside the aviary
Control 2	Hugin	Male	1995 Captive	26 months	2 boxes in the aviary
	Munin	Male	1995 Captive	26 months	2 boxes in the aviary
Control 3	Wota	Female	1995 Captive	26 months	2 boxes in the aviary
	Kaflunk	Male	1995 Captive	26 months	2 boxes in the aviary

Gender was estimated according to the behaviour and the body weight of the birds. Their age at the beginning of the experiment was calculated as the time after hatching. All birds were hand reared.

*The experiment lasted about 1 week, then these two birds were trained as models for the observer groups.

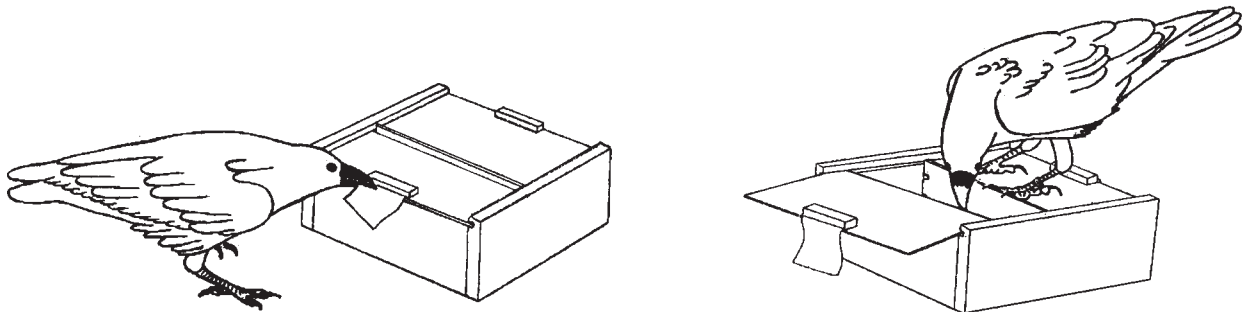

Figure 1. Diagram of the two opening techniques. The bird on the left side has started to open a lid by pulling on the flap, sitting in front of the box. The bird on the right has already opened the lid and is sitting on top of the box, reaching for the food reward inside.

box. This prevented the ravens from inserting their beaks between the divider and the lid and left pulling as the only option for opening.

The two opening techniques, levering and pulling, are qualitatively asymmetric, which means that they require different behavioural sequences and differ in the initial position of the animal (Fig. 1). When opening a lid by pulling, the ravens had to pass five steps, including one change in position: (1) approach the front of the box; (2) pull the flap; (3) jump on top of the box; (4) lever the lid completely open; and (5) get the reward. In contrast, opening by levering required only four steps without change in position: (1) jump on top of the box; (2) insert the beak by pecking between the lid and the central divider; (3) lever the lid open; (4) get the reward. The last two sequences of pulling and levering are identical.

Before the experiments started, food was regularly presented in the boxes without lids. This allowed the birds to habituate and to associate the boxes with food. During the experiment each of the two compartments per box

contained three pieces of meat (about 5 g each) as a food reward.

The experimental arena for the observers and for control group 1 contained six boxes (12 compartments), arranged regularly on an area of 3 × 3 m. For control group 1, this arena was placed outside the aviary, adjacent to, but visually isolated from, the individuals inside. During the following observer sessions we had to change the procedure, since the birds not involved in the experiment showed signs of stress inside the aviary (flying in panic and panting). Therefore, all the birds were allowed to fly freely during the day and we moved the experimental arena into the aviary. Only individuals that were actually involved in the experiment were brought inside the aviary. For the remaining birds outside, the nearest possible distance to the experimental arena was about 5 m. Thus, although the free birds could see the arena, they were hardly ever present during the experiments since they interacted with their wild conspecifics. Control dyads 2 and 3, tested in 1996, were isolated from one

another during the experiment in two different sections of their aviary. Because space was limited, their experimental arena contained only two boxes.

Procedure

The experimental series consisted of control sessions, model training and the observer sessions. Birds were always tested as dyads (model–observer or control–control) to avoid the need to single out individuals, which would have caused fear and, possibly, poor performance (Cheney & Seyfarth 1988; Schuster, *in press*).

The control dyads consisted of two birds reared in 1994 (dyad 1; Table 1) and four birds reared in 1995 (dyads 2 and 3; Table 1). The composition of the dyads was quasirandom. Birds were assembled on a first-come basis. The birds of dyad 1 were released from the aviary for several hours on each of the 8 experimental days and were free to enter the experimental area outside the aviary whenever they wanted. When a bird left the box after opening a lid, the experimenter replenished the reward and closed the lid again. Control dyads 2 and 3 were given two closed boxes. Their session was finished after 10 min or when the birds had opened all four compartments. This was repeated for 10 days with both dyads. In this case, compartments could not be refilled after opening, because these birds did not tolerate the experimenter on the arena without leaving. As a consequence of dyadic testing, observation and scrounging would have been possible for the control birds after one individual of the dyad started to open the lids.

After their control sessions, the birds of control dyad 1 were trained as models to demonstrate pulling to the observers. Strips of polystyrene were screwed on top of the boxes to prevent the birds from levering. That forced the candidate models to open the lids by pulling at the front flap. Thereby they trained themselves for later demonstration of pulling to the observers. For both birds, training lasted for 65 min within 5 consecutive days. Thereafter we started immediately with the observer series.

For the observer sessions, the experimental arrangement was moved into the aviary and only the observer–model dyads were allowed to enter. As in control dyad 1, the reward was replenished and the lid was closed. We started experiments by allowing the candidate observer to enter the experimental arena together with a model. In the initial session of the first observer the model stopped working after 9 min and was allowed to leave the area. Therefore, 9 min was kept as the standard time for the presence of a model in the initial session of each observer bird. After 9 min the observer was allowed to stay alone on the arena until it left voluntarily. During the second experimental session of the first dyad, the model stopped working after 2 min and, again, this time period was used as the standard for the other two observers. Therefore, all observers had the same time together with a model but differed in the total duration of the first two sessions. At the end of the second session all observers opened the lids independently of their model. In the following sessions the model again joined the observer from the beginning,

but was free to stay or leave. Two observers (Otto, Luu) were first tested in alternation. Then the sessions with Ara, the third observer, followed. Each observer was tested on 8 experimental days.

All series, control and observer, were videotaped and data were coded from tape. For every minute and for all animals on the arena, the frequencies of the following behaviours were recorded. (1) 'Jumping jack' (Gwinner 1964; Heinrich 1988): a fearful approach towards an object, where the bird first approaches by hopping sideways, then quickly grasps some part of the box with the tip of the beak, keeping the body at the furthest possible distance, followed by an immediate jump backwards, supported by wing flapping. Functionally and evolutionarily, this seems to be a 'testing-whether-the-carcass-is-dead' sequence. (2) Manipulations: any beak contacts with the box. (3) Scrounging (Barnard 1984): the model acts as producer, opening a lid and the observer immediately tries to get the exposed pieces of meat. (4) Opening the lid by levering or by pulling.

Coding of behavioural sequences was relatively straightforward. The entire database was coded from tape by one of us (J.F.). To control for bias, five persons with only limited prior knowledge of raven behaviour as well as J.F. independently scored the same videotape, containing 70 behavioural sequences. Control persons first watched a videotape with a commentary, which showed pulling, levering and jumping jacks, two actions in each case. They coded $96.5 \pm 1.1\%$ ($\bar{X} \pm SD$) of the 70 sequences in the same way that J.F. did. This indicates that these actions were clear and easy to distinguish and therefore the coding bias was negligible.

RESULTS

We found a clear differentiation between the control individuals and the observers. Within the controls and observers individual results were consistent, even though the control individuals of groups 2 and 3 were reared and tested under different conditions from those of control group 1.

Time until Opening

Control individuals and observers differed in two measures of latency (Table 2). All three observers made contact with the first box within their first minute on the arena, whereas in the control dyads the first contact of the initiating bird occurred within 2–19 min (Kolmogorov–Smirnov two-sample test: $Z=1.414$, $N=9$, $P=0.037$). The latency periods of the observers from the first contact with a box to the first independent opening was 0–15 min, whereas the four control individuals had a 4–37 min latency. However, this difference was not significant (Kolmogorov–Smirnov two-sample test: $Z=0.982$, $N=9$, NS).

The ratio of contacts with boxes during the presence and absence of the model is a measure of the influence of the model on the observer. The percentage of contacts with boxes, where the model was present, was 50% for

Table 2. The behaviour of observer and control individuals when they came into contact with boxes

Group	Subject	Time (min) to first contact with a box	Time (min) from first contact with a box to first opening	Behaviour at first contact with a box	Jumping jacks over the entire period	Opening frequencies ($\bar{X} \pm SD$) per min within 20 min of initial opening	
						Levering	Pulling
Observer	Ara	1	0	Scrounging*	1	2.50±1.64	0.90±1.17
	Otto	1	2	Scrounging	2	2.60±2.16	0.20±0.41
	Luu	1	15	Scrounging*	5	0.25±0.44	0.10±0.31
Control 1	Pele	19	20	Jumping jack†	4	0.60±0.75	
	Ili	24	4	Jumping jack	4	0.90±0.97	
Control 2	Hugin	7	37	Jumping jack	1	0.45±0.51	
	Munin	45		Jumping jack	1		
Control 3	Wota	2	36	Jumping jack	2	0.15±0.37	
	Kaflunk	27		Jumping jack	1		

In two dyads (controls 2 and 3) only one bird (Hugin, Wota) started to open the box.

*The behaviour at first contact with a box without a model was a jumping jack

†See text for definition.

Table 3. Performance of models and observers at the boxes during the initial 9 min of the experiments with observer–model dyads

Subject	Model behaviour			Observer behaviour	
	No. of lids opened per min ($\bar{X} \pm SD$)	No. of pulls (P) and levers (L) used to open lids*	Pulling rate (%)*	No. of box contacts	No. of contacts with boxes where a model was present
Ara	7.44±3.91	7 P/2 L	78	24	12
Otto	8.77±1.30	88 P/5 L	95	15	14
Luu	8.44±1.42	19 P/6 L	76	12	7

*Data were collected starting with the first independent opening by the observers.

Ara, 93% for Otto and 58% for Luu (Table 3). In comparison with a probability of 16.6% for random contact with one of the six boxes, each of the three observers showed a significant preference for boxes where the model was present (Ara: $\chi^2_2=25.0$, $P<0.001$; Otto: $\chi^2_2=76.5$, $P<0.001$; Luu: $\chi^2_2=19.0$, $P<0.001$). Thus, stimulus enhancement may account for at least two differences between control birds and observers: the shorter latency of observers until the first contact with a box and the preferences of the observers for boxes with a model present.

Furthermore, the behaviours at first contact differed between control individuals and observers (Table 2). At their first contact with a box, all control individuals oriented their behaviour towards the red front flap by performing a jumping jack. In contrast, when the observers first made contact with the box, where the model was present, they did not show jumping jacks, but attempted to scrounge instead by joining the model on top of the box. However, two of the observers performed jumping jacks at their first contact with a box in the absence of a model. Individual variation in the number of jumping jacks was high. The low number of jumping jacks in control groups 2 and 3 may be explained by the specific

hand-rearing conditions, which resulted in birds low in neophobia.

Opening Behaviour

The six control birds only levered lids open; none of them ever opened a box by pulling. In contrast, all observer birds showed both pulling and levering, from the beginning of independent opening (Fig. 2). For two of the three observers the first independent opening was by pulling. Out of the first three openings two observers opened twice by pulling (P) and once by levering (L) (sequence: LPP; PLP), whereas the third bird pulled only once (sequence: PLL). For two of the three observers (Otto and Luu) the pulling rates declined rapidly and they opened almost exclusively by levering, whereas the third observer Ara retained pulling at a relatively high frequency over the entire session (Fig. 2).

The two models were used in alternation. Both performed at relatively high opening frequencies during the first 9 min that they were with the observer on the arena (Table 3). They showed a clear preference for pulling.

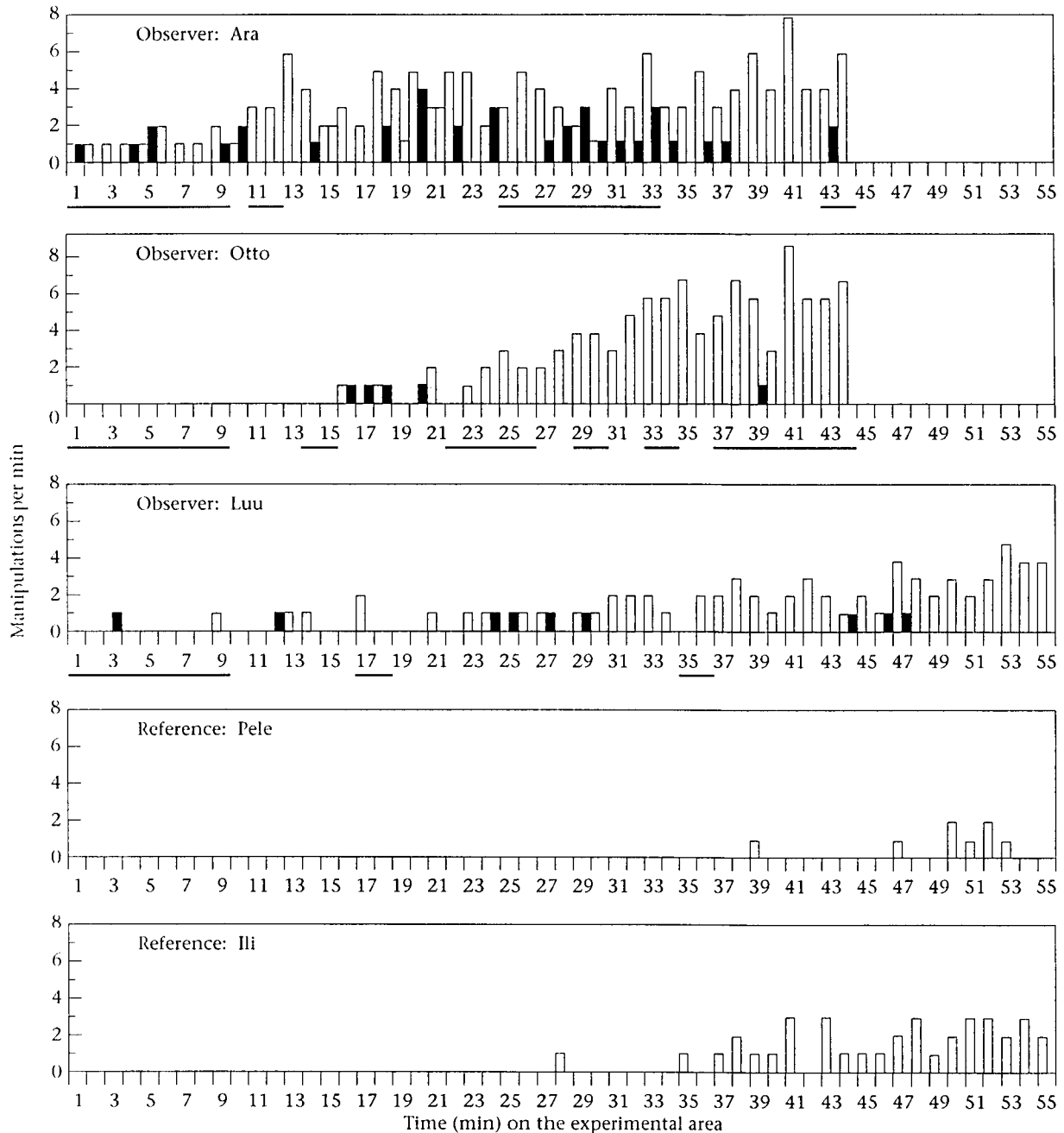

Figure 2. Number of individual lid openings by levering (\square) and pulling (\blacksquare) per min on the experimental arena. Data for the three observers and for Pele and Ili (control group 1) as representative examples for the control birds are shown. The black lines beneath the X axes of the observer graphs mark the periods when a model was present together with the observer.

Until the first independent opening by each observer, their models opened between 76 and 95% of the lids by pulling.

Scrounging

In both kinds of dyads, control-control and model-observer, birds had the opportunity to get food from boxes opened by conspecifics. In the model-observer dyads models never attempted to scrounge from the

observers. In contrast, all observers first scrounged to get access to food before they started to open lids themselves and even continued to scrounge thereafter (Table 4). However, the amount of food per compartment was limited and, therefore, not all the attempts to scrounge were successful. The rate of success at getting at least one of the three pieces of meat that the model had produced was between 23 (Luu) and 50% (Ara) in all attempts.

In contrast to the model-observer dyads, none of the birds in the control dyads ever obtained a reward by

Table 4. Scrounging behaviour within the observer–model dyads at the boxes during the first 9 min that the model and observer were together and during the entire session

Subject	Initial time with the model			Entire session		
	Minute of first scrounging attempt	No. of scrounging attempts	No. of successful scrounging attempts	No. of scrounging attempts	No. of successful scrounging attempts	% Successful scrounging attempts
Ara	1	8	2	16	6	37.5
Otto	1	9	3	16	8	50.0
Luu	1	3	1	13	3	23.1

scrounging. In control group 1 both ravens started to open seemingly independently of each other and showed no attempt to scrounge. In control groups 2 and 3 scrounging attempts occurred, but were not successful.

DISCUSSION

All observers clearly differed from the control individuals in their opening behaviour. In the following discussion we stress three different aspects: (1) the time birds took to open lids; (2) the mechanisms involved in learning to open the boxes; and (3) the scrounging behaviour of the observers.

Time until Opening

Enhancement coupled with individual learning is the prevalent cognitive mechanism to explain learning processes that may be mistaken for motor imitation (Zentall 1996). This mechanism directs the observers' attention towards a place (local enhancement or area copying) or towards an object (stimulus enhancement or object copying) where the model acts (Giraldeau 1997). Thus, the much shorter latency periods of all observers, compared to the control individuals, until they first touched a box can be attributed to enhancement. In addition, the first physical contact of all observers was with a box where the model was present. There they showed no fear-motivated behaviour (jumping jacks), as all control individuals did on their first contact with a box.

Reducing fear in the observers and focusing their attention towards the stimuli or conditions where the model acts can promote the acquisition of innovations and, therefore, further the formation of traditions (Giraldeau et al. 1994). Well-documented examples for the strong influence of these effects are the pine-cone stripping of black rats, *Rattus rattus* (Zohar & Terkel 1996) or the opening of milk bottles by great tits, *Parus major* (Sherry & Galef 1990). For wild ravens, a wealth of anecdotes deal with local traditions and the fast acquisition of innovations (Lorenz 1931; Heinrich 1989). Since naturally reared ravens are highly neophobic, the reduction of fear and the enhancement of attention towards the relevant stimulus should strongly

facilitate the learning process. This is shown in our experiment. However, our observer birds were not only more motivated to learn something at the box, but were seemingly also influenced with regard to their opening technique.

Opening Behaviour

During their first contact with a box all control birds showed jumping jacks, directed towards the red flaps. However, no control bird ever opened a box by pulling at this flap. In contrast, the observers first made contact with the boxes from the top, trying to scrounge from the model. Nevertheless, all observers started to open the box by pulling at the flap. Therefore, the initial pulling behaviour of the observers was probably caused by the specific influence of the models.

To investigate the social-learning mechanism that is responsible for the initial pulling behaviour of the observers, we need to focus on a specific methodological feature of our experiment. In studies with the proper two-action design, the two actions can be performed on the same part of the test apparatus. In this way, stimulus enhancement or observational conditioning can be ruled out as the mechanism responsible. However, in our experiment the initial position of the bird as well as the position of the relevant stimulus to open a lid were different for the two opening techniques. While levering, the bird sat on top of the box and inserted the bill between the interior rim of the lid and the central divider, whereas a bird that pulled the lid open started out in front of the box, and pulled on the red flap at the outer side of the lid.

Therefore, the difference between the observers and the controls may be due to increased motivation of the observers to explore the flap, applying a species-typical action, such as pulling, in a more vigorous manner than the controls. Palameta & Lefebvre (1985) found that observer pigeons were sufficiently motivated to pierce through a paper lid on a dish of food only when they saw models pecking through the lid and then eating the seeds beneath. Observer pigeons who saw models either pecking through the lid to an empty dish or eating through an already made hole in the lid did not learn to peck through the lids themselves. Galef (1988) commented that models

who pierce and eat are possibly better stimulus enhancers than either eating or piercing models. A similar kind of interpretation is possible for the behaviour of the ravens. All birds are likely to explore the flap but only observers will be sufficiently motivated and free of fear to direct sustained and vigorous actions towards the flap and then to learn through their own efforts that pulling at the flap causes the lid to move. Therefore, stimulus enhancement seems to be a sufficient mechanism to explain our main results.

However, Palameta & Lefebvre's (1985) study also indicates that imitation learning cannot be ruled out as the mechanism involved. Their observers learned only when they saw the model both piercing and eating. This suggests that the pairing of a demonstrator's response with a secondary reinforcer is of crucial relevance for the observers. Akins & Zentall (in press) obtained similar results for Japanese quail, which learned a demonstrator's response only when they observed the demonstrator subsequently eating the reward. In our experiment, pulling, demonstrated by the model, included manipulation at two specific sites, first in front of the box to pull the flap, then at the slit on top of the box in order to reach the reward. Acting at the two sites clearly differed with respect to its spatial and temporal connection with the reward. Only the manipulation on top of the box was immediately rewarded and should, therefore, have had greater associative strength than pulling at the flap. Since manipulation on top of the box enabled the bird to open the lid by levering, an observer interested in the position where the model gained access to the reward should manipulate at the interior rim of the lid and consequently open by levering, not by pulling. Therefore, it remains unclear which mechanism led the observers to start pulling the flap. Either stimulus enhancement directed the observer's attention not to the stimulus most closely connected to the reward but to the one the model first made contact with, or the observers imitated the sequence of pulling. We certainly cannot distinguish between these two possible mechanisms. However, our results indicate that observational learning acts at a very finegrain level in ravens.

Scrounging

Some studies have shown that individuals who had the opportunity to scrounge never performed the specific task needed to get access to the food themselves (Barnard & Sibly 1981; Giraldeau & Lefebvre 1987). To prevent scrounging is one of the reasons why previous experiments on social learning have physically separated the model from the observer. This, however, does not preclude scrounging attempts. In an experiment with marmosets (Bugnyar & Huber 1997) for example, the observers tried to get food from the model through the wire mesh, but with little success.

All our observers scrounged before they started to open lids on their own and they continued to scrounge even after opening the lids themselves. In studies where the scroungers never began to perform the task (e.g. Barnard & Sibly 1981; Giraldeau & Lefebvre 1987), the quantity of

food present and, therefore, potential scrounging success was higher than in our experiment, where the three pieces of meat were subject to exploitation competition between scroungers and producers. Whether individuals continue scrounging seems to depend on its profitability compared with the profitability of being a producer. Therefore, the opportunity to obtain food through scrounging does not necessarily prevent the scroungers from learning the task (Broom & Ruxton 1998). Furthermore, being a successful scrounger under these circumstances requires careful observation of, and behavioural coordination with, the behaviour of the producer. These are conditions expected to be essential for learning by observation, especially for motor imitation (Visalberghi & Frigaszy 1990; Coussi-Korbel & Frigaszy 1995). Therefore, scrounging may even have the potential to enhance social learning.

In nature, ravens a few months old such as our three observers still form a family group with their parents. Close spatial proximity, typically found in such families, is supposed to be an important prerequisite for scrounging as well as for observational learning (Coussi-Korbel & Frigaszy 1995; Frigaszy & Visalberghi 1996). Therefore, our ravens might have been at their life history optimum concerning their predisposition for learning from a model. Further research may show whether this hypothesis is valid. However, we have shown that learning in ravens can be very specifically influenced by observation of an experienced conspecific. This may have, on an ultimate level, important implications for understanding the considerable ecological flexibility of ravens.

Acknowledgments

We are grateful to T. Bugnyar for assistance and, together with L. Huber, E. Thaler, B. Völkl and B. Zisser, for comments on the manuscript. We particularly thank two anonymous referees for their detailed and constructive comments. We thank H. Pechlaner and D. Schratler from the Vienna Zoological Garden Schönbrunn for the ravens, the 'Herzog von Cumberland-Stiftung' and the Cumberland Wildpark Grünau for permanent support. Funding was provided by the OeNB-Jubiläumsfond Project 5288, by the 'Verein der Förderer' and by the sponsorship of MAYR-Schulmöbel.

References

- Akins, C. K. & Zentall, T. R. 1996. Imitative learning in male Japanese quails (*Coturnix japonica*) involving the two-action method. *Journal of Comparative Psychology*, **110**, 316–320.
- Akins, C. K. & Zentall, T. R. In press. Imitation in Japanese quails: the role of reinforcement of demonstrator responding. *Psychonomic Bulletin and Review*.
- Barnard, C. J. 1984. The evolution of food-scrounging strategies within and between species. In: *Producers and Scroungers: Strategies of Exploitation and Parasitism* (Ed. by C. J. Barnard), pp. 95–126. New York: Chapman & Hall.
- Barnard, C. J. & Sibly, R. M. 1981. Producers and scroungers: a general model and its application to captive flocks of house sparrows. *Animal Behaviour*, **29**, 543–550.

- Broom, M. & Ruxton, G. D. 1988. Evolutionary stable stealing: game theory applied to kleptoparasitism. *Behavioral Ecology*, **9**, 397–403.
- Bugnyar, T. & Huber, L. 1997. Push or pull: an experimental study on imitation in marmosets. *Animal Behaviour*, **54**, 817–831.
- Byrne, R. W. 1995. *The Thinking Ape: Evolutionary Origins of Intelligence*. Oxford: Oxford University Press.
- Byrne, R. W. & Tomasello, M. 1995. Do rats ape? *Animal Behaviour*, **50**, 1417–1420.
- Campbell, F. M. & Heyes, C. M. In press. A demonstration of stimulus enhancement in the rat using a two-lever paradigm. *Canadian Journal of Psychology*.
- Cheney, D. & Seyfarth, R. M. 1988. Social and non-social knowledge in vervet monkeys. In: *Machiavellian Intelligence: Social Expertise and the Evolution of Intelligence in Monkeys, Apes and Humans* (Ed. by R. W. Byrne & A. Whiten), pp. 34–53. Oxford: Clarendon.
- Cook, M., Mineka, S., Wolkenstein, B. & Laitsch, K. 1985. Observational conditioning of snake fear in unrelated rhesus monkeys. *Journal of Abnormal Psychology*, **93**, 355–372.
- Coussi-Korbel, S. & Frigaszy, D. M. 1995. On the relationship between social dynamics and social learning. *Animal Behaviour*, **50**, 1441–1453.
- Dawson, B. V. & Foss, B. M. 1965. Observational learning in budgerigars. *Animal Behaviour*, **13**, 470–474.
- Fragaszy, D. M. & Visalberghi, E. 1996. Social learning in monkeys: primate 'primacy' reconsidered. In: *Social Learning in Animals: The Roots of Culture* (Ed. by C. M. Heyes & B. G. Galef, Jr), pp. 291–316. San Diego: Academic Press.
- Galef, B. G. 1988. Imitation in animals: history, definition and interpretation of data from the psychological laboratory. In: *Social Learning: Psychological and Biological Perspectives* (Ed. by T. Zentall & B. Galef), pp. 3–28. Hillsdale, New Jersey: L. Erlbaum.
- Galef, B. G., Jr, Manzig, L. A. & Field, R. M. 1986. Imitation learning in budgerigars: Dawson & Foss (1965) revisited. *Behavioral Processes*, **13**, 191–202.
- Gardner, M. & Heyes, C. M. In press. Limitation of the bidirectional control procedure. *Canadian Journal of Psychology*.
- Giraldeau, L. A. 1997. The ecology of information use. In: *Behavioural Ecology* (Ed. by J. R. Krebs & N. B. Davis), pp. 42–68. Oxford: Blackwell Science.
- Giraldeau, L. A. & Lefebvre, L. 1987. Scrounging prevents cultural transmission of food-finding behaviour in pigeons. *Animal Behaviour*, **35**, 387–394.
- Giraldeau, L. A., Caraco, T. & Valone, T. 1994. Social foraging: individual learning and cultural transmission of innovations. *Behavioral Ecology*, **5**, 35–44.
- Gwinner, E. 1964. Untersuchungen über das Ausdrucks- und Sozialverhalten des Kolkraben. *Zeitschrift für Tierpsychologie*, **21**, 656–747.
- Heinrich, B. 1988. Why do ravens fear their food? *Condor*, **90**, 950–952.
- Heinrich, B. 1989. *Ravens in Winter*. New York: Simon & Schuster.
- Heinrich, B. 1995. Neophilia and exploration in juvenile common ravens, *Corvus corax*. *Animal Behaviour*, **50**, 695–704.
- Heyes, C. M. 1994. Social learning in animals: categories and mechanisms. *Biological Reviews*, **69**, 207–231.
- Heyes, C. M. 1996. Genuine imitation? In: *Social Learning in Animals: The Roots of Culture* (Ed. by C. M. Heyes & B. G. Galef, Jr), pp. 371–404. San Diego: Academic Press.
- Heyes, C. M. 1998. Theory of mind in nonhuman primates. *Behavioral and Brain Science*, **21**, 101–148.
- Heyes, C. M., Dawson, G. R. & Nokes, T. 1992. Imitation in rats (*Rattus norvegicus*): initial responding and transfer evidence. *Quarterly Journal of Experimental Psychology*, **45B**, 229–240.
- Huber, B. 1991. Bildung, Alterszusammensetzung und Sozialstruktur von Gruppen nichtbrütender Kolkraben. *Metelener Schriftenreihe für Naturschutz*, **2**, 45–59.
- Kabicher, G. & Fritz, J. 1996. Handaufzucht von Kolkraben: Über die Faszination sich entfaltenden Lebens. *Öko L*, **18**, 21–28.
- Lorenz, K. 1931. Beiträge zur Ethologie sozialer Corviden. *Journal für Ornithologie*, **34**, 67–127.
- Moore, B. R. 1992. Avian movement imitation and a new form of mimicry: tracing the evolution of a complex form of learning. *Behaviour*, **122**, 231–263.
- Nicol, C. J. & Pope, S. J. 1994. Social learning in small flocks of laying hens. *Animal Behaviour*, **47**, 1289–1296.
- Palameta, B. & Lefebvre, L. 1985. The social transmission of a food-finding technique in pigeons: what is learned. *Animal Behaviour*, **33**, 892–896.
- Promberger, C. 1992. Wölfe und Scavenger. M.Sc. thesis, University of Munich.
- Schuster, R. In press. The cooperative behaviour of dyads. *Canadian Journal of Psychology*.
- Sherry, D. F. & Galef, B. G., Jr. 1990. Social learning without imitation: more about milk bottle opening by birds. *Animal Behaviour*, **40**, 987–988.
- Thorpe, W. H. 1963. *Learning and Instinct in Animals*. London: Methuen.
- Visalberghi, E. & Fragaszy, D. M. 1990. Do monkeys ape? In: *Language and Intelligence in Monkeys and Apes. Comparative Developmental Perspectives* (Ed. by S. T. Parker & K. R. Gibson), pp. 247–273. Cambridge: Cambridge University Press.
- Whiten, A. & Byrne, R. W. 1988. Taking (machiavellian) intelligence apart: editorial. In: *Machiavellian Intelligence. Social Expertise and the Evolution of Intelligence in Monkeys, Apes and Humans* (Ed. by R. W. Byrne & A. Whiten), pp. 50–65. Oxford: Clarendon.
- Whiten, A., Custance, D. M., Gomez, J. C. & Teixidor, P. 1996. Imitative learning of artificial fruit processing in children (*Homo sapiens*) and chimpanzees (*Pan troglodytes*). *Journal of Comparative Psychology*, **110**, 3–14.
- Zentall, T. R. 1996. An analysis of imitative learning in animals. In: *Social Learning in Animals: The Roots of Culture* (Ed. by C. M. Heyes & B. G. Galef, Jr), pp. 221–243. San Diego: Academic Press.
- Zentall, T. R., Sutton, J. E. & Sherburne, L. M. 1996. True imitative learning in pigeons. *Psychological Science*, **7**, 343–346.
- Zohar, O. & Terkel, J. 1996. Social and environmental factors modulate the learning of pine-cone stripping techniques by black rats, *Rattus rattus*. *Animal Behaviour*, **51**, 611–618.